

LightShield

TECHNICAL FEATURES



Description

LightShield is a multi-purpose light signaling solution with a magnetic base. Practical and portable, usable in the road or industrial environment. Also rechargeable individually

OPTICAL FEATURES

Light source	27 LEDs	
Optics	360° + front	
Colour	Amber	Blue
Flashing modes	12 for the single module; 5 for the synchronized operation	

ELECTRICAL FEATURES

Power supply	Rechargeable lithium battery
Power consumption	25 W
Charge time	4 hours
Autonomy	20 hours
Power charger	100-240 Vac and 12/24Vdc with cigarette lighter adapter (USB cable for the recharge)
Insulation class	Class III

MECHANICAL FEATURES

IP protection degree	IP65
Flare weight	145 g
Kit case weight	4.5 Kg
Flare dimensions	90 x 80 x 22 mm
Kit case dimensions	365 x 340 x 107 mm
Flare materials	Polycarbonate, Thermoplastic Polyurethane and Aluminum Alloy
Kit case material	Polypropylene
Fixing	Magnetic base, belt pockets and magnetic cone holders
Operating temperature	-20 °C ÷ +55 °C



Rev. 3.0
11/10/2023

Approved TEC

Approved AQ

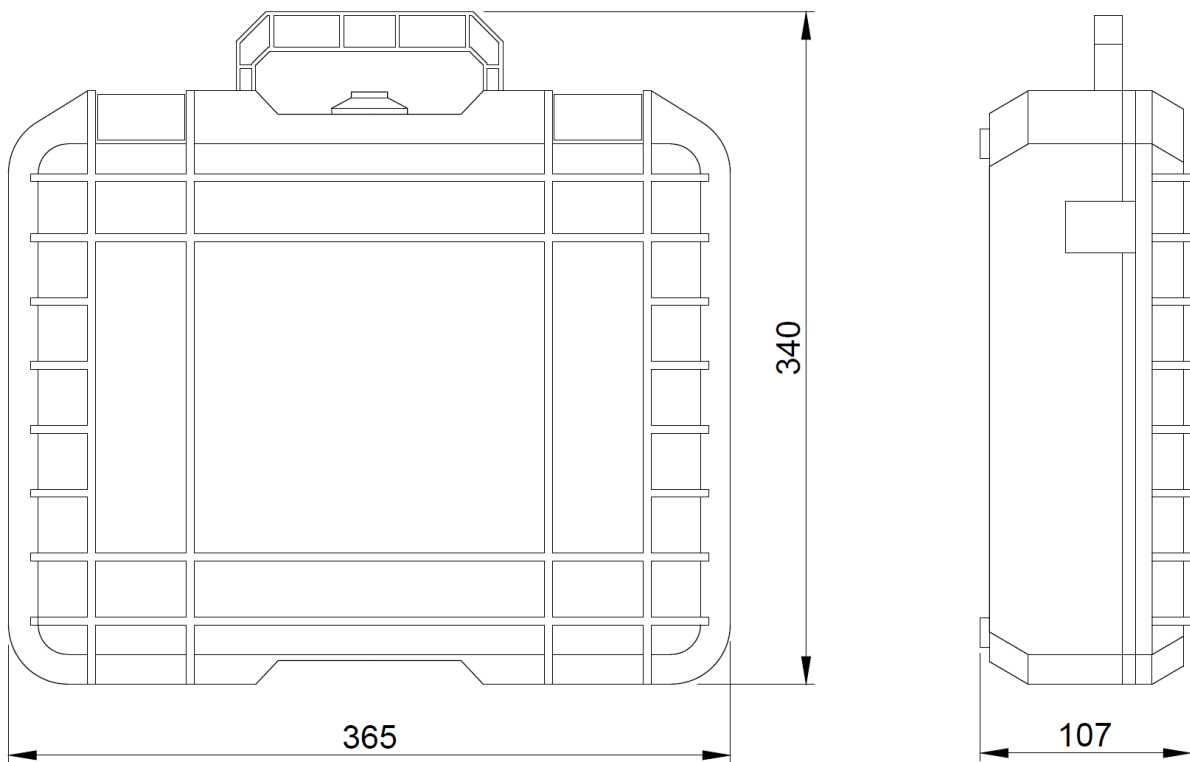
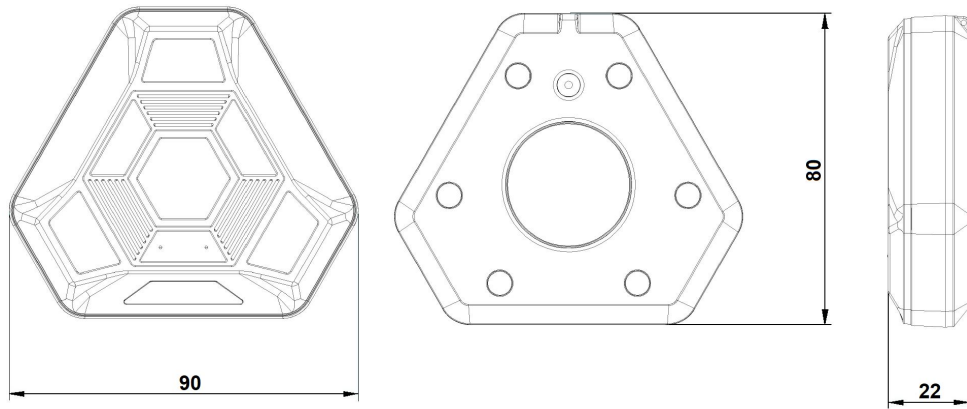

Rev. 3.0
11/10/2023

Approved TEC

Approved AQ